

TEMPERATURE SENSOR

type 293

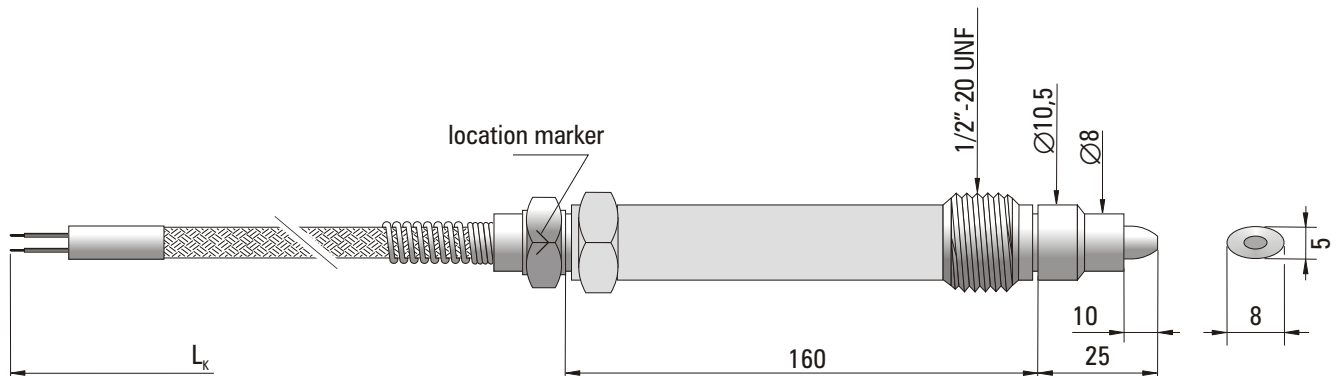

SPECIFICATION

Application	temperature measurement of feed cylinders extruding presses and injection molds. The location marker enables orientation setting of the oval measuring tip.
Temperature range	0°C... +500°C
Measuring element	Fe-CuNi (J) NiCr-NiAl (K)
Class of thermocouple	2 ⁽¹⁾
Measuring junction	grounded ⁽¹⁾
Sheath material	steel 1.4541 ⁽¹⁾

⁽¹⁾ Other parameters according to customer requirements

⁽²⁾ Other sensor dimensions on demand

ORDERING CODE

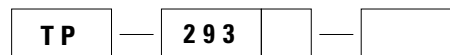

Measuring element **J** or **K**

Length of compensation cable $L_x = 1, 2$ or 3 m⁽¹⁾

Example for order: TP-293J-3,0 thermocouple sensor Fe CuNi (J), length of compensation cable $L_x = 3$ m.