

TEMPERATURE SENSOR

type 371

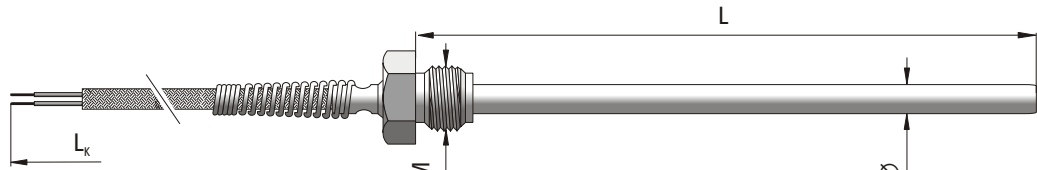

type 372

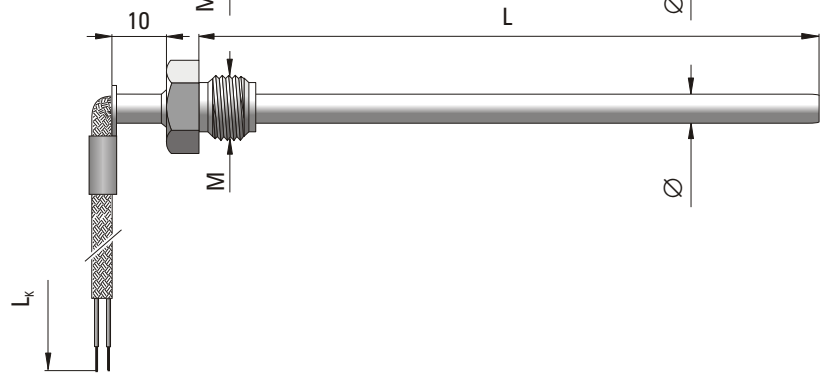

SPECIFICATION

Temperature range	-40°C... +400°C
Measuring element	platinum resistor (Pt100)⁽²⁾ thermocouple Cu-CuNi (T) thermocouple Fe-CuNi (J) thermocouple NiCr-NiAl (K)
Class of processing element	2 (B)
Measuring junction	insulated ⁽¹⁾
Sheath material	steel 1.4541
Fitting (M)	welded stationary fitting with thread M6, M8x1, M10x1, M12x1,5, M20x1,5, G1/2" ⁽¹⁾
Cable insulation	fiber glass and steel braid ⁽³⁾

⁽¹⁾ Other parameters according to customer requirements

⁽²⁾ Pt500, Pt1000, Ni100, Ni1000 on demand

⁽³⁾ Other cable insulation: PVC, silicon, PTFE, stainless steel armored sheath on demand

Option	W1	W2	W3	W4	W5	W6	W7
Sensor length L (mm) ⁽¹⁾	50	100	200	300	400	600	800
Length of the cable L _k (m) ⁽¹⁾	0,5	1	1	1	1,5	1,5	1,5

ORDERING CODE



Sensor type **371, 372**

Measuring element **Pt100, T, J or K**

Sheath outer diameter $\varnothing = 2,5, 3, 4, 5, 6, \text{ or } 8 \text{ mm}$

Option **W1 ... W7**

Welded stationary fitting with thread **M6, M8x1, M10x1, M12x1,5, M20x1,5, G1/2"**⁽¹⁾

Example for order:

TP-371J-5-W5-M10x1 thermocouple sensor Fe-CuNi (J) of outer diameter $\varnothing = 5 \text{ mm}$, length L = 400 mm, length of the cable L_k = 1,5 m with welded stationary fitting with metric thread M10x1.