

TEMPERATURE SENSOR

type 387

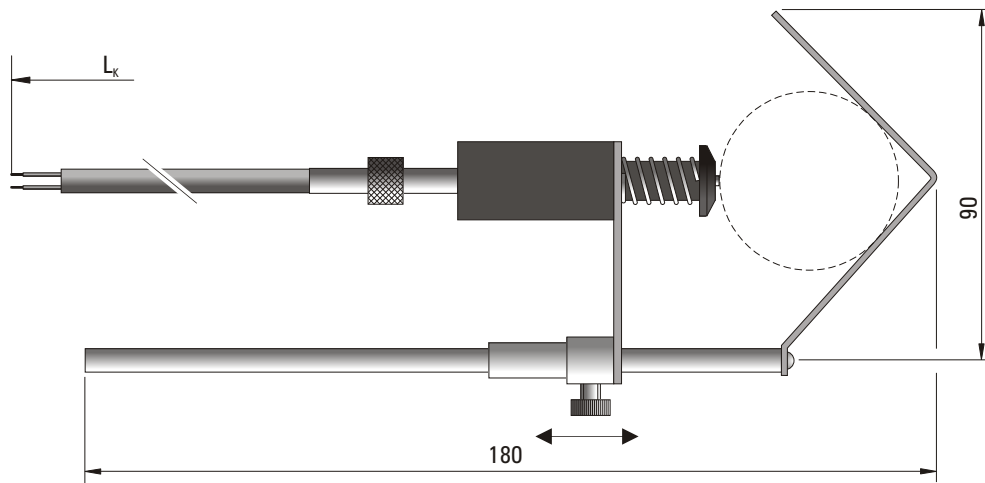

SPECIFICATION

Application	temperature measurement of pipelines and other cylindrical elements of outer diameter in range from 25 mm to 80 mm
Temperature range	-40°C... +150°C
Measuring element	Cu-CuNi (T) Fe-CuNi (J) NiCr-NiAl (K)
Class of thermocouple	2 ⁽¹⁾
Measuring junction	grounded ⁽¹⁾
Response time T _{0,9}	25 sec.
Cable operating temperature	-30°C... +80°C
Additional accessories	plug type MT

⁽¹⁾ Other parameters according to customer requirements

ORDERING CODE

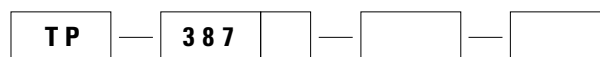

Measuring element **T, J, K**

Length of compensation cable L_k = **0,5, 1,5 or 2,5 m**⁽¹⁾

Additional accessories: plug type **MT**

Example for order: TP-387J-1,5 thermocouple sensor Fe-CuNi (J), length of compensation cable L_k = 1,5 m.