

TEMPERATURE SENSOR

type 528

SPECIFICATION

Application	temperature measurement of diesel engine exhaust gas, especially in shipping engines
Temperature range	-40 °C...+800 °C
Measuring element	thermocouple NiCr-NiAl (K) ⁽¹⁾
Class of thermocouple	1
Measuring junction	insulated ⁽¹⁾
Sheath	drilled thermowell, high pressure resistant
Sheath material	steel 1.4541
Fitting (M)	M27x2, G3/4" ⁽²⁾
Immersion length (L)	100, 150, 200 mm ⁽¹⁾
Admissible vibrations	80Hz, 5g
Maximum operating pressure	12MPa
Maximum speed of flow	
gas	70m/s
liquid	5m/s
Connection head type	NA, IP54, 100 °C
Additional accessories	compensation cable temperature transmitter

⁽¹⁾ Other parameters and dimensions according to customer requirements
⁽²⁾ Other inch and metric threads on demand
⁽³⁾ Connection head with protection class IP65 or acid resistant on demand

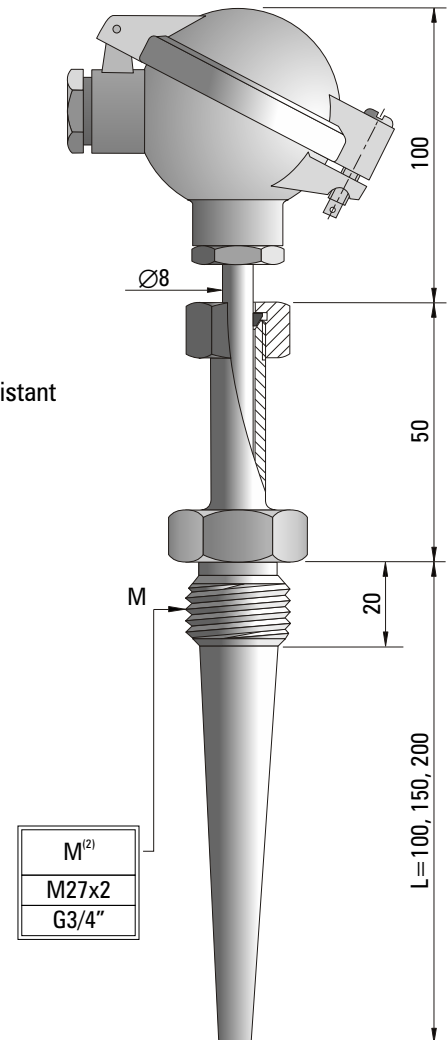

ORDERING CODE

Single **(1)** or double **(2)** measuring element
 Sensor length L = **100, 150** or **200** mm⁽¹⁾
 Thread size M = **M27x2, G3/4**"⁽¹⁾
 Option with the head-mount transmitter **T**

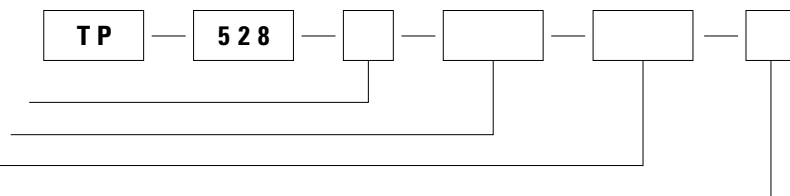

Example for order: TP-528-1-100-M27x2 sensor with single thermocouple NiCr-NiAl (K) with sheath of length L=100mm and thread M27x2.
 TP-528-1-100-M27x2-T; TCH-2160-K sensor with the head-mount transmitter type TCH-2160-K.